

The → mark shows the piping direction.

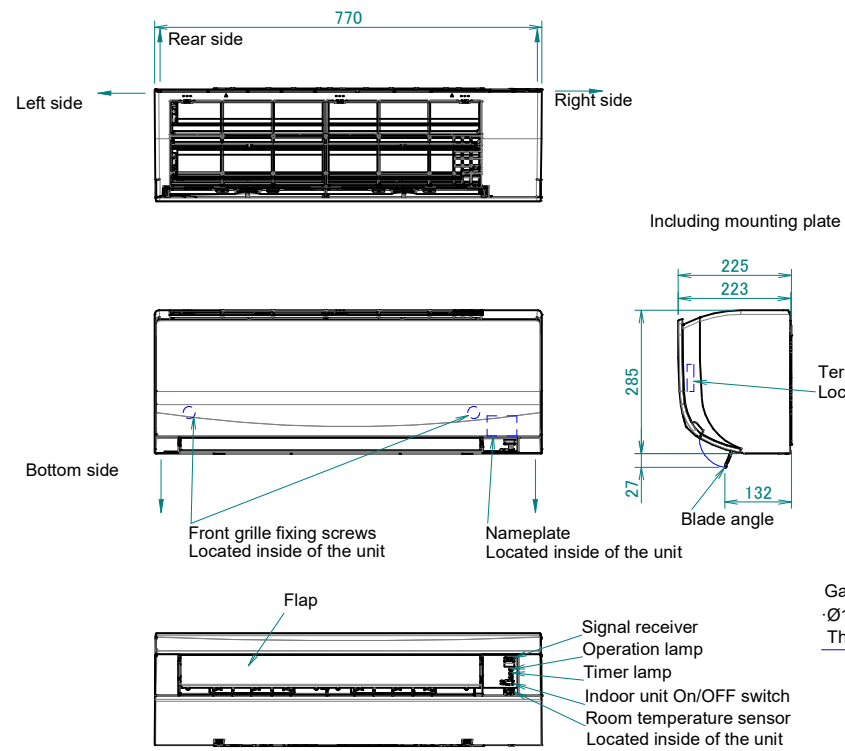

Required space for service and ventilation

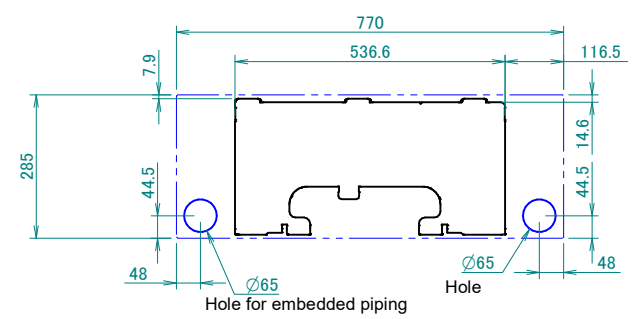
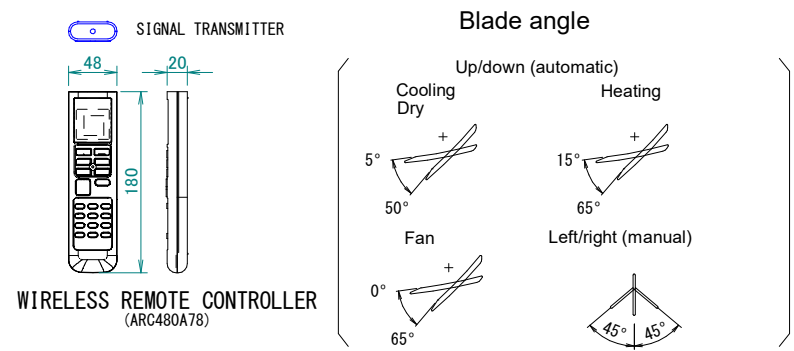
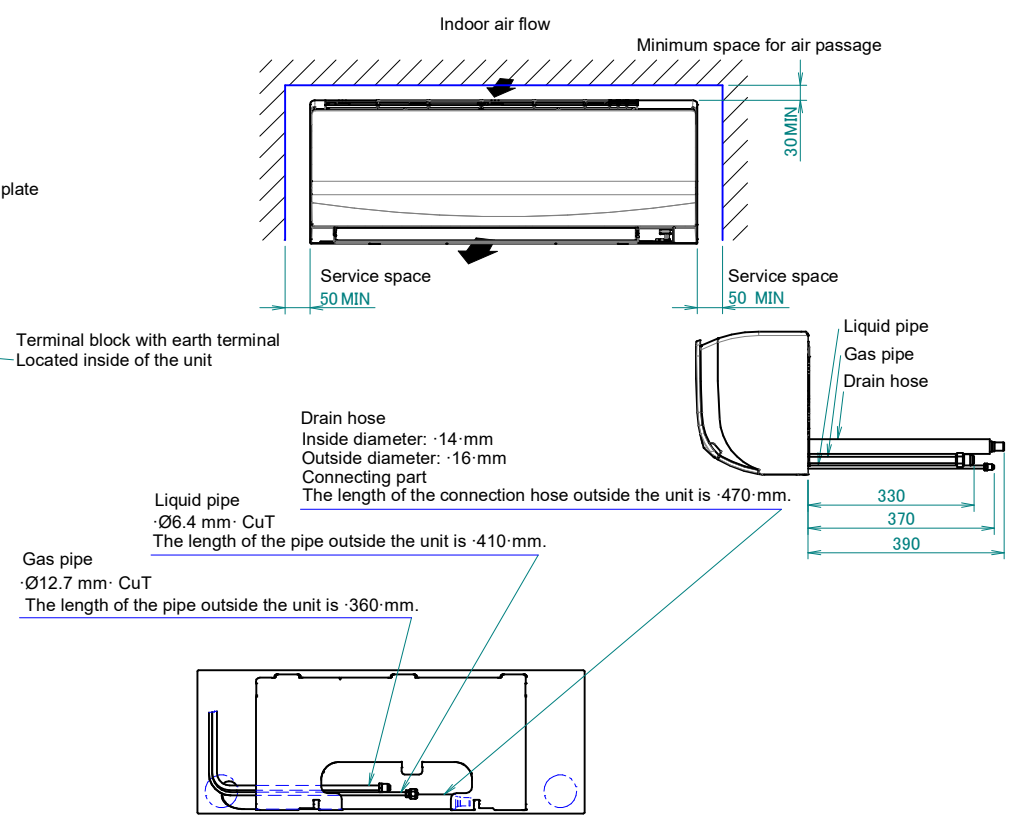

Standard location of holes in the wall