

5 Dimensional drawings

5 - 1 Dimensional Drawings

5

EHVX-E3V
EHV(H-X)-E6V
EHV(H-X)-E9W
EHVX-E6VG

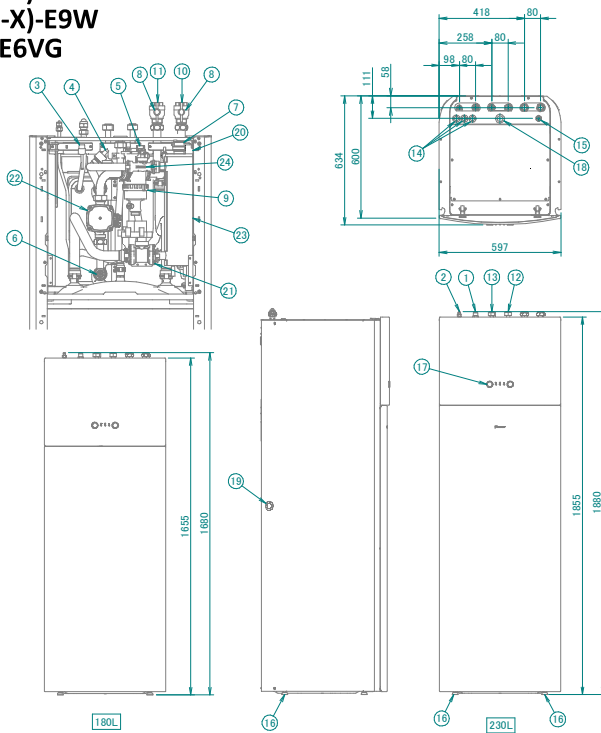

- ① Gas pipe connection ·Ø 15.90mm· flare
- ② Liquid pipe connection ·Ø 6.35mm· flare
- ③ Refrigerant pressure sensor
- ④ Space heating water pressure sensor
- ⑤ Safety valve
- ⑥ Drain valve water circuit
- ⑦ Air purge
- ⑧ Shut-off valve
- ⑨ Magnetic filter / dirt separator
- ⑩ Water in connection ·1" F BSP·
- ⑪ Water out connection ·1" F BSP·
- ⑫ Domestic hot water: cold water in ·3/4" F BSP·
- ⑬ Domestic hot water: hot water out ·3/4" F BSP·
- ⑭ High voltage wiring intake ·Ø 24mm·
- ⑮ Low voltage wiring intake ·Ø 15mm·
- ⑯ Levelling feet
- ⑰ User interface
- ⑱ Recirculation connection ·G 3/4"· (female)
- ⑲ Drain outlet (unit + safety valve)
- ⑳ Expansion vessel
- ㉑ 3-way valve
- ㉒ Pump
- ㉓ Backup heater
- ㉔ Flow sensor

Screws used in this unit:

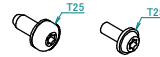

The typical field installation has to be done according to the applicable legislation.

For examples, refer to the installer reference guide.

3D112072B